

VANDAL RESISTANT DOOR ENTRY SYSTEMS



Entrypoint

INSTALLATION INSTRUCTIONS

IN_5140 980609

SRS
THE ACCESS CONTROL
SPECIALISTS



AUDIO DOOR ENTRY SYSTEMS



KEYPAD ACCESS CONTROL



VIDEO DOOR ENTRY SYSTEMS



CARD & PROXIMITY ACCESS CONTROL



VANDAL RESISTANT DOOR ENTRY



ELECTRIC LOCKING DEVICES

TEL : ^{national call} **0870 010 1001**

FAX : 0870 010 2001 WEB : www.srstacs.co.uk

842 - 850 Coronation Rd, Park Royal, London, NW10 7QJ

INDEX

Battery backup	4
Connector set	10
Egress button	11
Entrance panel.....	10
Fireman's switch	11
Getting Started	3
Isolated telephone control board.....	6
Keypad	11
Lock release	11
Lock timer	11
PAC	11
Power supply	4
System Buss	4
Standard functional telephone control board	6
Stocko connector	3
Strobes	9
Telephones	8
Time clock	5
Tradesman time clock.....	5
Wiring diagrams	12 - 15
Wiring recommendations	3

What kind of door entry system are you fitting?

Basic systems

In this system the cables usually run from the entrance panel to each successive phone in a building. If a fault develops in any phone or in the cable, the entire system may be affected. It is not usually possible to isolate a faulty phone from the system. This is because each phone has two cables attached to it, one in from the previous phone and one out to the next. When a fault develops, the entire system may go out of action. This kind of system does not normally use the 5140 power supply (as covered by this manual).

Standard functional telephone entry system

In the SRS EntrypointT standard functional door entry system cables are run from the power supply to each individual phone. Whilst the entire system may be affected if a fault develops in an individual phone, the faulty phone - or cable linked to it - can be disconnected by unplugging it at the power supply. There is a potential wait for an engineer, but the problem is restricted.

With each telephone having only one cable, installation is far neater and easier to manage than for the basic system. The system can be upgraded to an isolated system by changing the telephone control board.

Isolated telephone entry system

A telephone on an SRS EntrypointT isolated system works totally independently of all others. Cables are laid in exactly the same way as in the SRS EntrypointT standard functional door entry system. The phones are connected into the system only when called. Only one telephone can be "live" on the system at any time. If a fault develops in any phone, the system is not affected. The faulty phone or cable is automatically isolated by the system control board (5115).

Wiring recommendations

We recommend that all equipment is installed according to the relevant British Standards. Attention is drawn to the Regulations for Electrical Installation (16th Edition) and MP 1337 and MPT 1339 (DTI Radio communications division). We recommend the use of twisted paired solid core cable - British Telecom specification - Type CW1308. All tests on SRS equipment rely on this type of cable. Interference may be caused if other cable types are used.

Getting started

You know what cable to use (CW1308) and the type of system you are installing (isolated or standard functional). Now you can begin to install the equipment. The power supply is the connection point for all cables, it therefore makes sense to mount it first. Do not make any connections yet...

You should use the colour coding suggested in the wiring diagrams. You will have better results if you do. Do not make any connections in the power supply until you have fitted and connected the phones and entrance panel(s). Once everything is in position you will run through some tests and then commission the system.

You should have a telephone pre wired on a short lead with a stocko plug fitted to help with commissioning.

- 1 Phones are connected using either the connector board (5108 or 5116) or with isolated system (5115). In each case the connections can be made by using a pre wired lead which plugs into the power supply and the respective board. No other equipment should be connected into the SYSTEM BUS.
- 2 Only SRS telephones should be used on the system.
- 3 Each telephone must have a separate cable to the power supply unit.
- 4 All spare cables must be connected to terminal 6 (ie. -ve).
- 5 Alternative to 5115 isolated system is 5116 non isolated system. Connection information is identical, but functions are less.

Using the stocko connector

All connections to the telephone control boards are made with "stocko" connectors. They offer reliable connection and can be unplugged easily for testing. The stocko plug will only fit into the socket in one position and therefore the wires can approach from only one direction.

Strip the outer cable sleeve back by 40mm.

Insert the individual wires into the plug so that they come all the way through the connector

Using a large pair of pliers evenly compress the plug so that the wires are trapped.

Trim back the protruding ends

Entrypoint power supply

The 5140 power supply is the heart of EntrypointT. All power outputs are individually fused. The "TRADES" time clock is simple to use. The lock release timer is adjustable 0 - 60 seconds. The SYSTEM BUSS connectors make interconnection with other pcb's simple.

The 5140 is supplied as standard in a lockable box which accepts one additional control board (5140LE accepts two). All control boards are the same size. If more control boards are required add 5133 which accepts 2 control boards (same lockable box as 5140) or 5133LE which accepts 3 control boards (same lockable box as 5140LE)

5140 can be supplied complete with telephone control boards. For example 514008 is a 5140 with a built in 5108 board for 8 telephones, 514016 is the same except for 16 telephones and 514015 is assembled with a 5115 isolated telephone control board for 8 telephones.

NOTE: Systems requiring more boards can be supplied. Please specify 5140LE and the boards required, and we will provide a box to suit. All SRS EntrypointT control boards (i.e. 5108, 5116, 5136 and 5137) are an identical size.

Standby battery

This output is for a rechargeable battery - NOT a dry cell. A 12 v battery can be charged if the battery leads are fitted into the battery charger connector CON5 on the right hand side of the power board. 'RECH BATT' green LED will indicate power is OK.

The System BUSS

The system buss allows quicker connection of the wires common to the system. All SRS control boards are connected using the system buss ribbon cable. The common wires are:

- DM** switched +ve for door monitoring LED. This terminal is ultimately connecting the red LED in the telephone (terminal 8) to 12v dc via the microswitch in the lock release.
- 2** This terminal is ultimately connecting the microphone in the telephone (terminal 2) to the audio amplifier 5150 (terminal 2).
- 1** This terminal is ultimately connecting the speaker in the telephone (terminal 1) to the audio amplifier 5150 (terminal 1).
- 6** Common negative. This terminal is connected to common terminal 6 on telephone via permanent connection through the telephone control board.
- 9** This terminal is ultimately connecting the lock release button (terminal 9) in the telephone to the lock release relay timer.
- 12** Fused 12v dc 2 ampere. This can be used to provide power to 5115 and telephone accessories (eg 5127 timed strobe). Do not use inductive load (ie. telephone buzzers) on this power rail. Green LED indicates power is OK.
- R** Only used on isolated systems. System wide reset connection is automatic to all boards requiring the facility. This connection is a termination allowing the reset signal from one part of a system to pass to other parts of the same system.

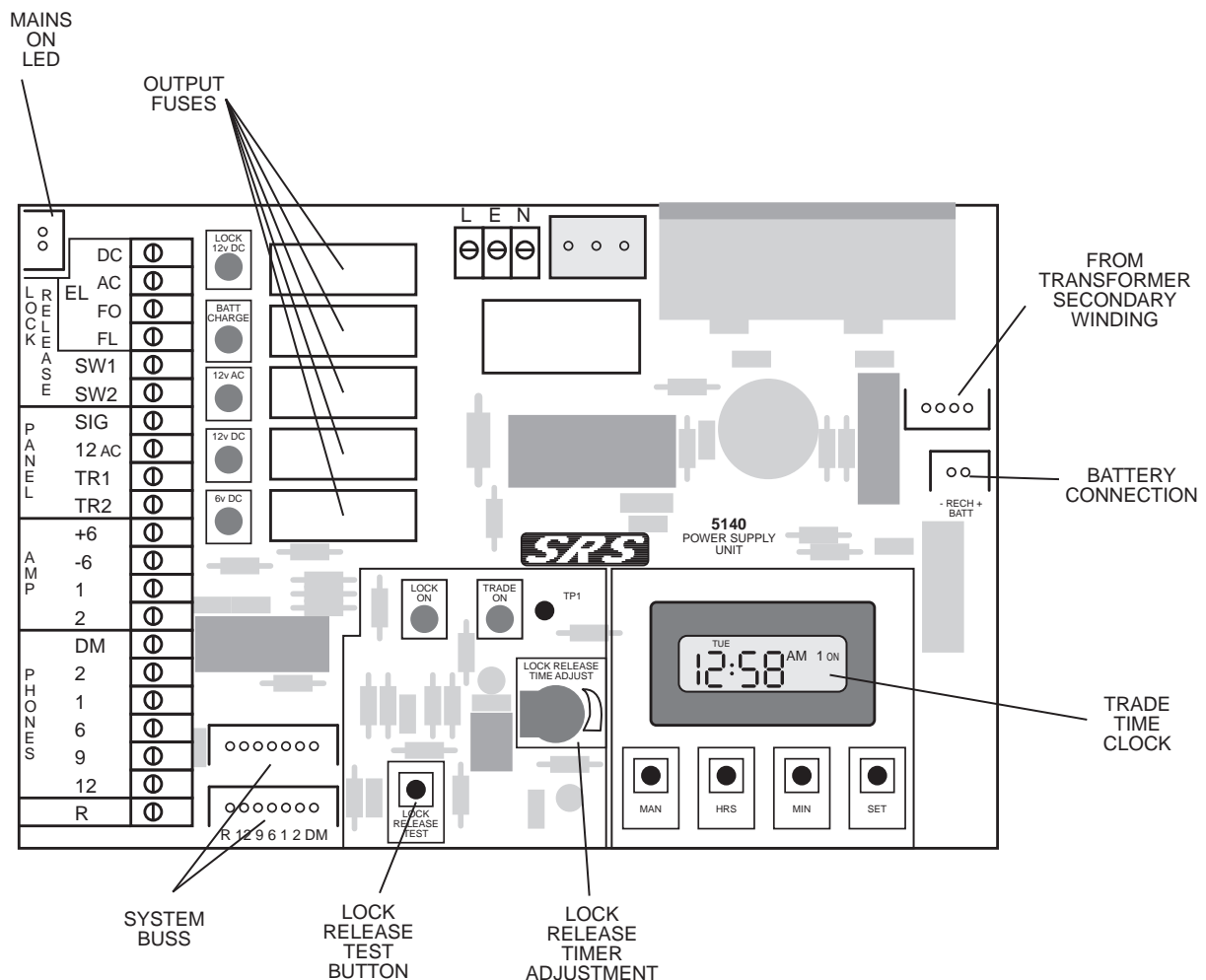

Setting the time clock

1 Select Mode

A slide switch on the circuit board allows you to select either 24 HR (ie. every day set the same) or 5 + 2 mode (weekdays set the same and week ends set the same). In 5 + 2 mode the day of the week is also displayed.

Note : Press and hold the button to advance rapidly.

2 Reset

Press and hold all buttons together (for about 2 seconds). This resets the memory. The Colons will flash.

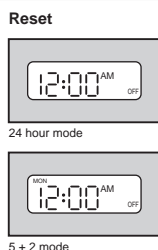

3 Setting Time

Press **SET** and the colons will stop flashing. A flashing "T" will indicate **SET TIME** mode. Press **HRS** to set hours, **MIN** to set minutes. In 5 + 2 mode press **MAN** to set the day.

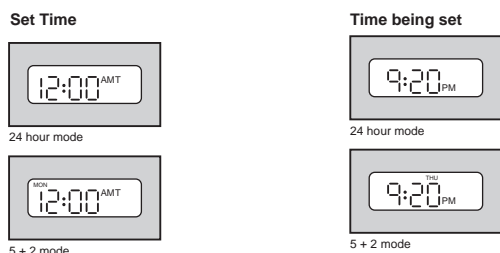

4 Set Programme

Press **SET** and get into **SET PROGRAMME** mode.

The first ON event can be set by using HRS and MIN buttons as described above.

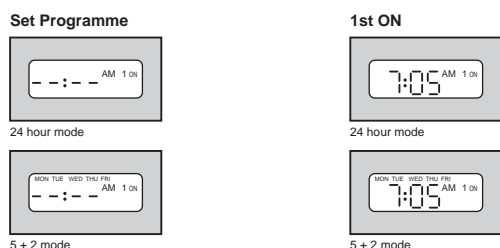

In 5 + 2 mode

MONTUE WEDTHU FRI

is additionally displayed to show the event being set applies to weekdays only.

Once the first ON event is obtained, press **SET** and then use **HRS** and **MIN** to set the first OFF event.

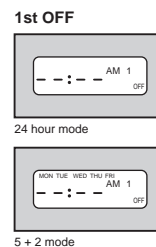

The second / third ON and OFF events can be set using the same procedure.

In 24 HR mode, once the third OFF event has been set, pressing set will return the module to RUN mode.

In 5 + 2 mode, once the third OFF event for weekdays has been set, pressing SET will allow the first ON event of the weekend to be set.

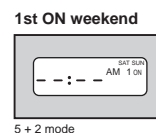

The remaining ON and OFF weekend events are programmed using the same procedure as for weekdays.

NOTE : All events do not have to be programmed if not required.

A programme once set, can be reviewed by pressing **SET** to sequence through the events. Events can easily be reset by using **HRS** and **MIN** buttons.

5 Suspend

A previously programmed event can be suspended by displaying it using the SET button and pressing the MAN button. An X will be displayed to show the event has been suspended.

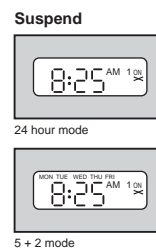

6 Cancelling

An event can be cancelled by using the SET button to display the event. Press HRS until a dash is displayed for hours and then press MIN until dashes appear for minutes. Return to run mode by tabbing through the programme using the SET button.

7 Run Mode

When in run mode, the colons flash and the current time is displayed. Alternatively the output status is shown.

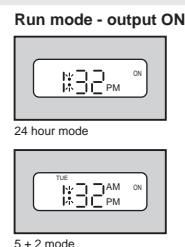

8 Manual Override

When in run mode, pressing the **MAN** buttons reverses the output of the current event. The programme will revert back to normal at the next event. To indicate manual override the output status will flash.

Telephone control boards

5108 standard functional telephone control board

The SRS Entrypoint connection system improves efficiency and reduces the risk of mistakes. Each telephone, is wired back to the telephone control board. Connection is simple, primarily via the system buss (ribbon cable). As many boards as required for the number of flats in the system may be connected.

Once connected, calls are automatically routed to the correct phone. Damaged or vandalised phones can be removed from service by unplugging them.

You should use the colour coding suggested in the wiring diagrams. You will have better results if you do. Also see page 3 for "Using the stocko connector"

5115 Isolated telephone control board

The 5115 is supplied for connection as a junction board for up to eight telephones per board. As many 5115's as required for the installation may be connected in parallel (using the system buss). The 5115 enables any called telephone to be connected and provides a timed tone call (0-30 seconds). Only the last telephone to be called will be connected to the system. Should a phone be left off the hook (or damaged in any way) it will not interfere with the system. LED indicators show the status of functions at a glance.

SRS 5115 control board electronically isolates the phones and connects only the called phone into the system. All connections are crimped and unpluggable, making servicing simple and removing the likelihood of connection errors. Connection to the 5140 is via the system buss (ribbon cable) saving time and preventing errors. Various alternative modes of operation can be selected.

- full isolation and secrecy of conversation
- system BUSS connection
- Reset system upon hanging up the phone
- Reset system upon operation of lock release
- Adjustable call time (which resets when call is answered)
- LED indication as to connection made to flat.
- Reassurance tone (when pressing a button on the entrance panel)
- Busy indication at entrance panel (multi entrance systems)
- The board will automatically reset the system in the event that a call is unanswered after a predetermined and adjustable time up to two minutes.
- Full LED indication as to status of system.
- Plug-in test points.
- unpluggable telephone terminations

Call time adjustment

The duration of the tone generated by the 5115 can be varied between 0 seconds and 30 seconds. Set the time to give approximately 20 seconds by adjusting variable resistor VR2. If the call is not answered within the set time the 5115 will reset the system.

Connection timer

Adjustable 0 - 120 seconds (approximately). This sets the maximum amount of time that a telephone can be connected to the system for. Normally you would leave VR1 set to maximum. The connection can be cancelled early by setting either or both switches :-

SW1 set to ON if you require phone connection to be terminated and the system to reset upon operation of lock release button
SW2 set to ON if you require system to reset upon hanging up of telephone.

You should use the colour coding suggested in the wiring diagrams. You will have better results if you do. Also see page 3 for "Using the stocko connector"

Special outputs

The 5115 has two special output terminals:-

- A** Reassurance tone output (+12v dc). This a short 12v dc pulse which is present each time the 5115 receives a signal from a call button on the entrance panel.
- B** Busy signal output (+12v dc). This 12v dc signal lights up a busy LED fitted in the entrance panel. The LED will remain lit whilst the 5115 allows connection to a telephone.

5108 standard functional telephone control board

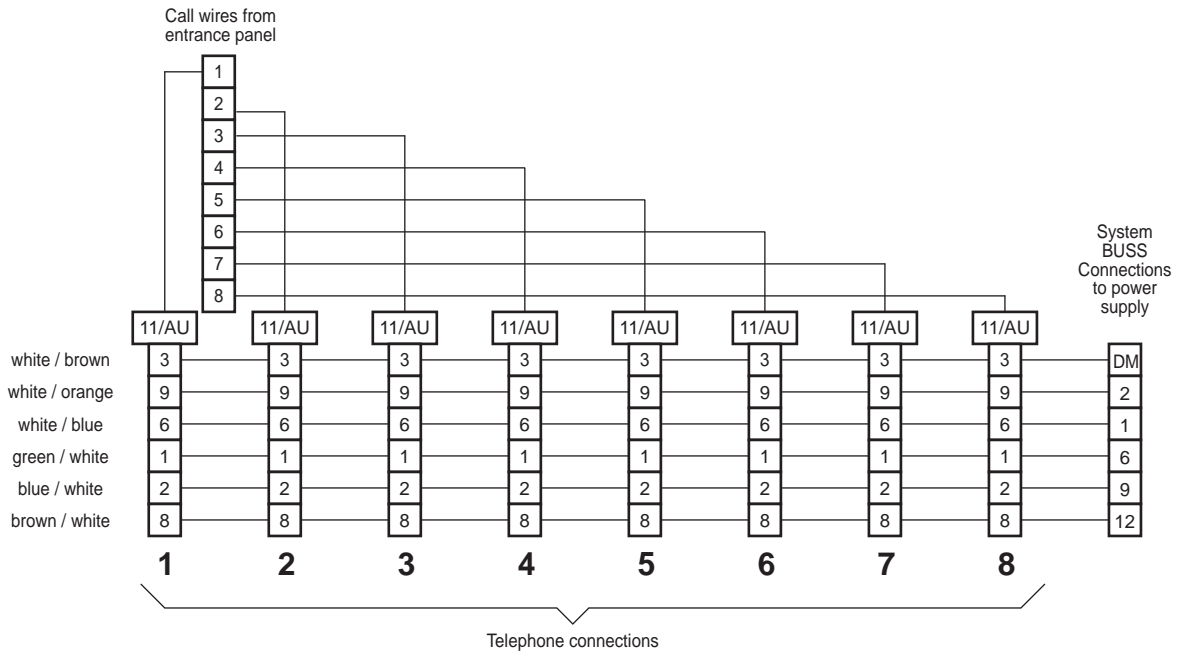

5115 isolated telephone control board

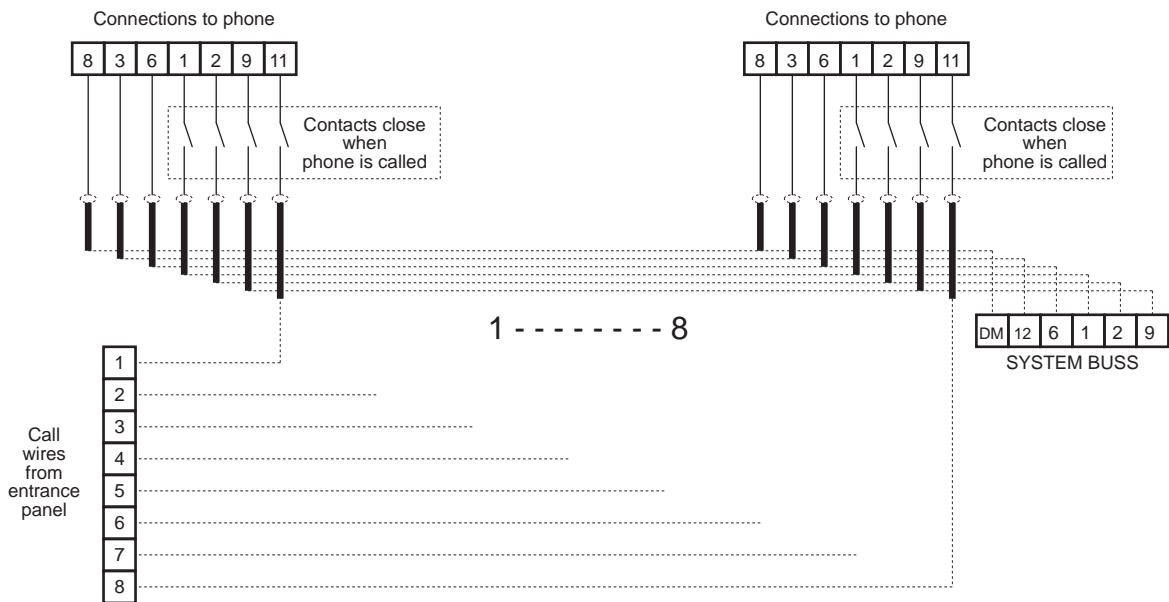

Telephone handset

The EntrypointT system offers a choice of 5 telephones. From a simple phone (AN0002) to a sophisticated telephone offering timed nuisance switch, door monitoring LED's and nuisance On / Off LED indication.

No limit to the number of phones on system, simply add telephone control boards for the required number of telephones.

You have a choice of calling the telephone with either a tone through the speaker in the handset or 12v dc to the buzzer. You should use the colour coding suggested below and in the wiring diagrams. You will have better results if you do.

See the chart below to decide on the telephone which best suits your needs.

	Privacy switch	Green LED to indicate privacy 'on'	Red LED to indicate door open	Lock release button	12v dc buzzer	12v ac buzzer	Tone call
AN0002			●		●	●	
AN1000			●		●	●	
AN7320			●		●	●	
AN7577	●	●	●			●	
70055	■	●	●			●	

■ Timed (up to 12 hours)

Notes for connection to an isolated system

Each phone is separately connected back to its respective termination plug on the telephone control board (5115). Only one phone is connected at a time and therefore secrecy of conversation is maintained. Lifting a handset (without having been called) will not allow connection to the system. The lock release can only be operated from a called phone and only by first lifting the handset.

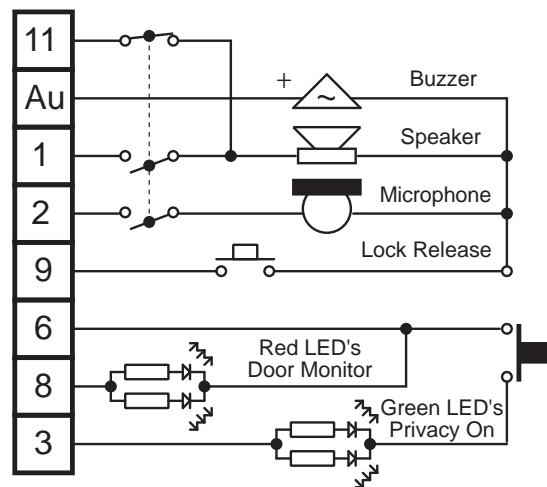

cable colour	5108	5115	phone	connected to (in phone)
brown / white	8	8	8	door monitor LED's
blue / white	2	2	2	microphone via hook lever switch
green / white	1	1	1	speaker via hook lever switch
white / blue	6	6	6	common negative
white / orange	9	9	9	lock release button
white / brown	3	3	3	nuisance indication LED's
orange / white	11 / Au	11		speaker (for tone call)
orange / white	11 / Au			buzzer (for buzzer call)

Connecting a strobe

refer to the 5126 installation instructions

The 5126 strobe timer can be adjusted between 0 and 60 seconds duration. The 5126 strobe timer once triggered will not accept another trigger signal until it has timed out. If the trigger signal is presented for longer than the set time the unit will re trigger immediately after timing out. The trigger terminals will trigger the timer from many dc and ac sources. Both terminals must be connected to the circuit for the timer to operate.

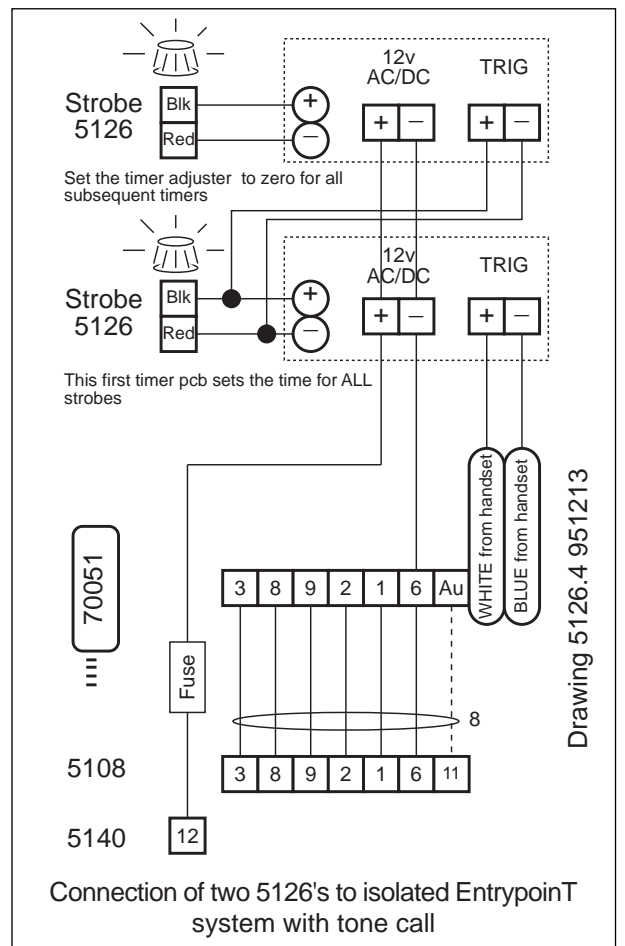
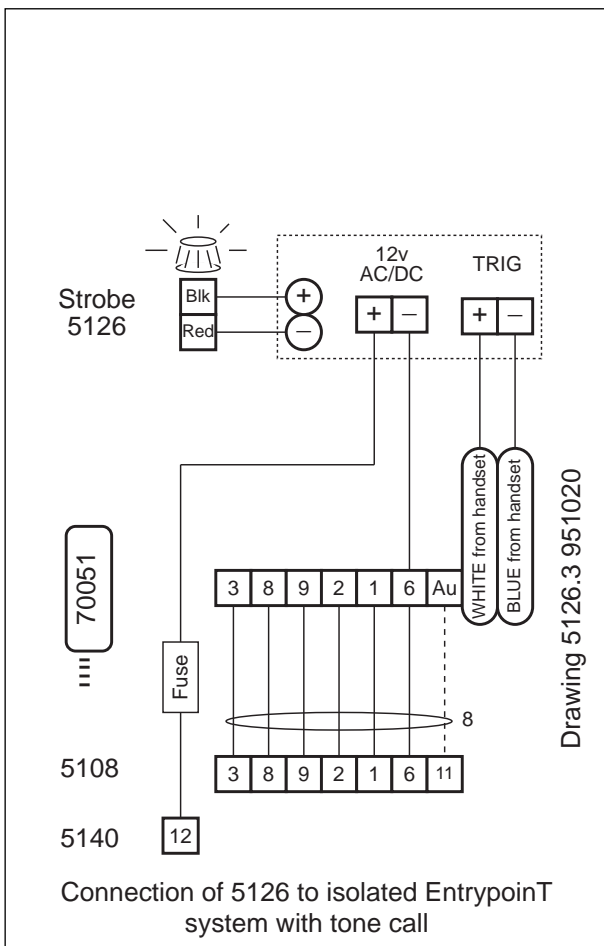
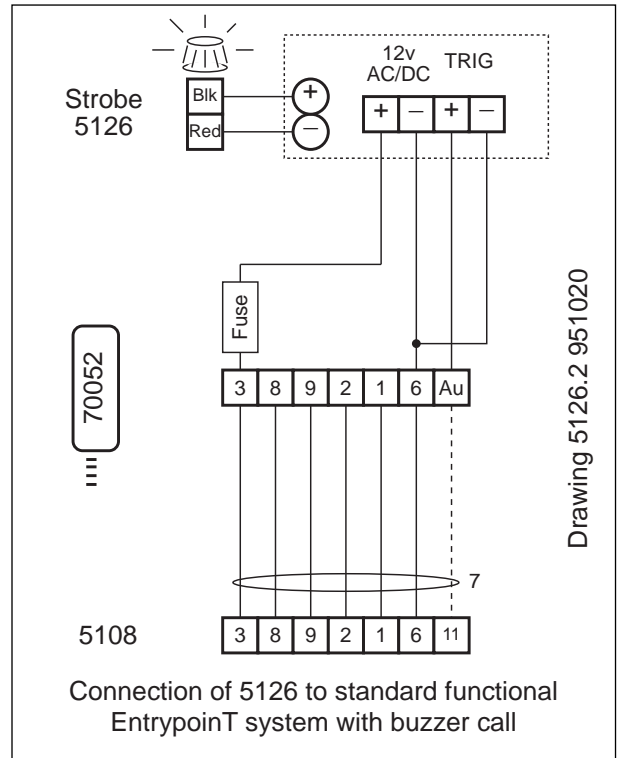
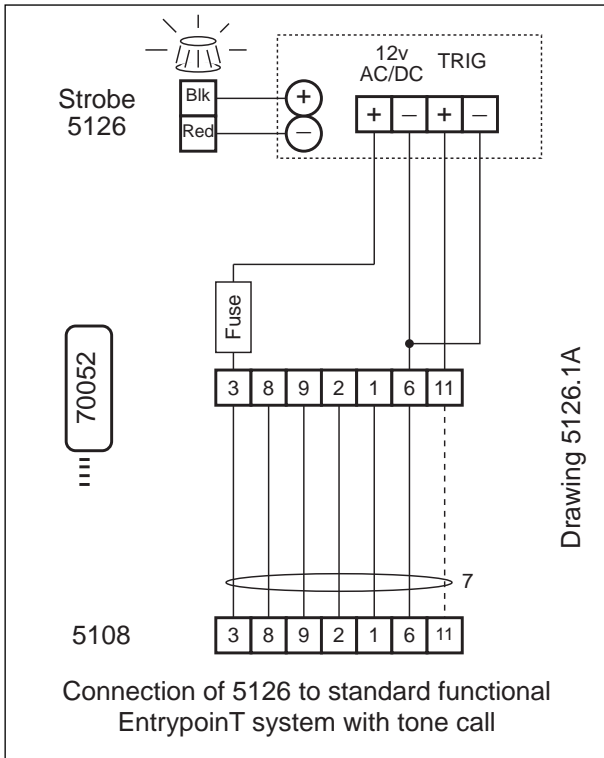

Entrance Panel

The stainless steel entrance panel is available flush mounting. It can be supplied with a mitred bezel frame for added protection. If you require to surface mount add a frame.

The back box should be embedded so that the amplifier sits at a height of approximately 1500 mm from the ground level. It is important that the front edge of the box is flush with the face of the wall. A number of problems may arise if the back box is incorrectly fitted.

Connections

SIG Connection to common of call buttons ISOLATED SYSTEMS ONLY

12AC Connection to common of call buttons NON ISOLATED SYSTEMS ONLY for systems which use 12 v ac buzzers.

TR1 Connection to tradesman button

TR2 Connection to tradesman button

It is often the case that the large number of wires from the push buttons lead to confusion, broken wires and short circuits. To avoid these problems the Entrypoint panels are pre wired.

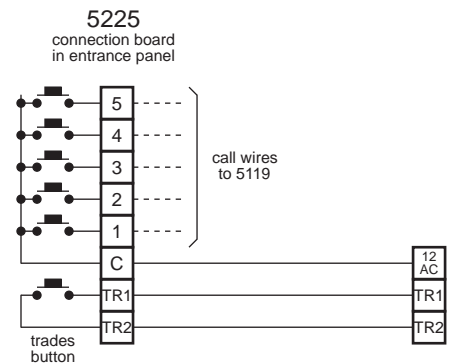

connection for systems using 5119 telephone connection board

5150 Speaker / amplifier

Inside the entrance panel is the combined speaker / amplifier unit which provides audio communication with the telephones. The 5150 speaker / amplifier unit is constructed with stainless steel for greater resistance to vandalism.

12 12v dc supply for 5150.

-6 Amplifier -ve

1 Connection from microphone of 5150

2 Connection to speaker of 5150

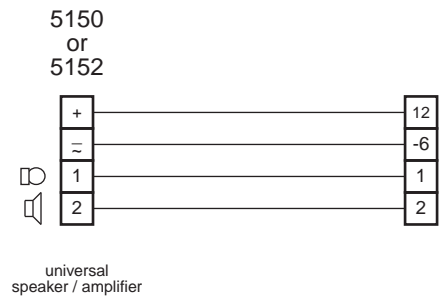

Lock Release

The timer circuit on the 5140 power supply board triggers a relay. The output from this relay switches a negative through to the lock release.

Opening Time

Setting of the opening time between 1 and 30 seconds is carried out by means of a potentiometer located in the lower centre of the pcb. Recommended time is 6 - 8 seconds.

Test Button

Pressing the 'LOCK RELEASE TEST' button mimicks the action of the button on the telephone handset for releasing the lock. The 'LOCK ON' LED will illuminate.

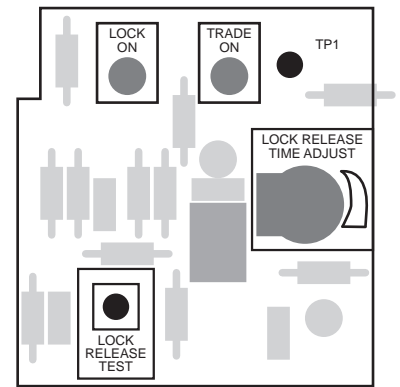

Lock Release 12v ac fail locked

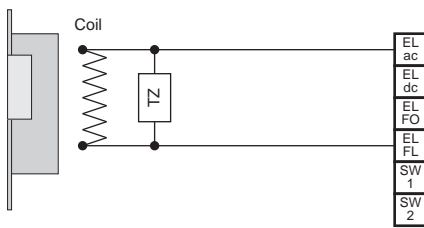

TZ = Transient suppressor

Lock Release 12v dc fail unlocked with monitoring

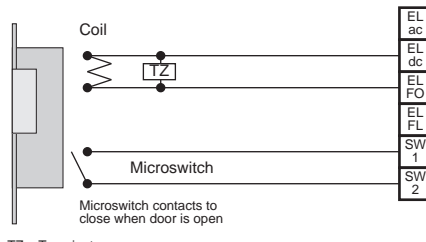

TZ = Transient suppressor

Lock Release 12v dc fail locked with monitoring

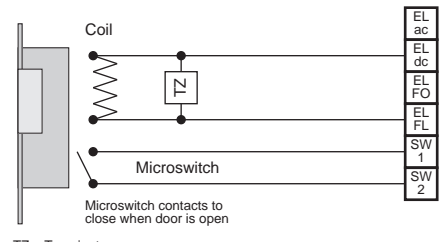

TZ = Transient suppressor

Door Monitoring

SW1 feeds 12v dc to the microswitch in the lock releases which is returned to SW2. The 5140 routes this signal to DM on the SYSTEM BUSS and Phone terminal 8. The cable to the lock should be run independently of any other cables to reduce noise.

- 1 Maximum current drawn by the lock release must not exceed 2 amps (fail locked) or 1 amp (fail unlocked). For releases requiring larger current, an additional power supply should be used.
- 2 The connection and operation of any locks by other means than those described above may damage the power supply and must therefore be avoided (this includes the connection of a push to break switch in series with magnetic locks).
- 3 Connection for door monitoring should be to the Normally Open terminals of a monitored electric release which must be capable of handling 2 amps across the relay contacts.
- 4 Cables to any lock releases on the system must be run independently of cables to the entrance panels (or any cables which carry call wires)

Connecting a fire override switch

When fire override switch is requested the lock release specified should be fail safe. In this case you connect a N/C (normally closed) switch in series with the circuit to the lock release. When the switch is operated the circuit breaks and the fail unlocked device will unlock.

Connecting an egress switch

Closing a switch across 6 & 9 triggers the timer circuit. If the lock is required to be operated by another means other than trades button (as discussed below) then a normally open switch can be connected in the diagram below. The 'LOCK ON' LED will illuminate when pressed.

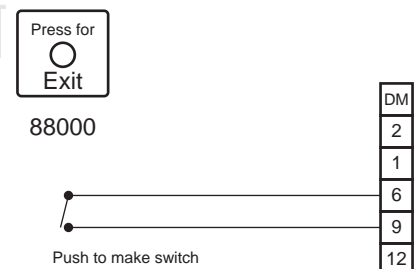

Connecting to access control

Connecting a keypad, proximity system (eg PAC) or card reader controller to the Entrypoint power supply is done in the same way as connecting an egress button. Use the closing relay output of your keypad (or whatever you are connecting) to terminals 6 and 9 of the 5140.

The DC30M keypad module also takes its power (12v dc) from the 5140.

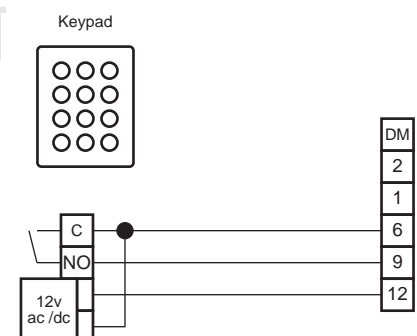

Standard Functional System

Drawing 3D_5140 1E SF 970919

- electronic tone call
- one entrance panel

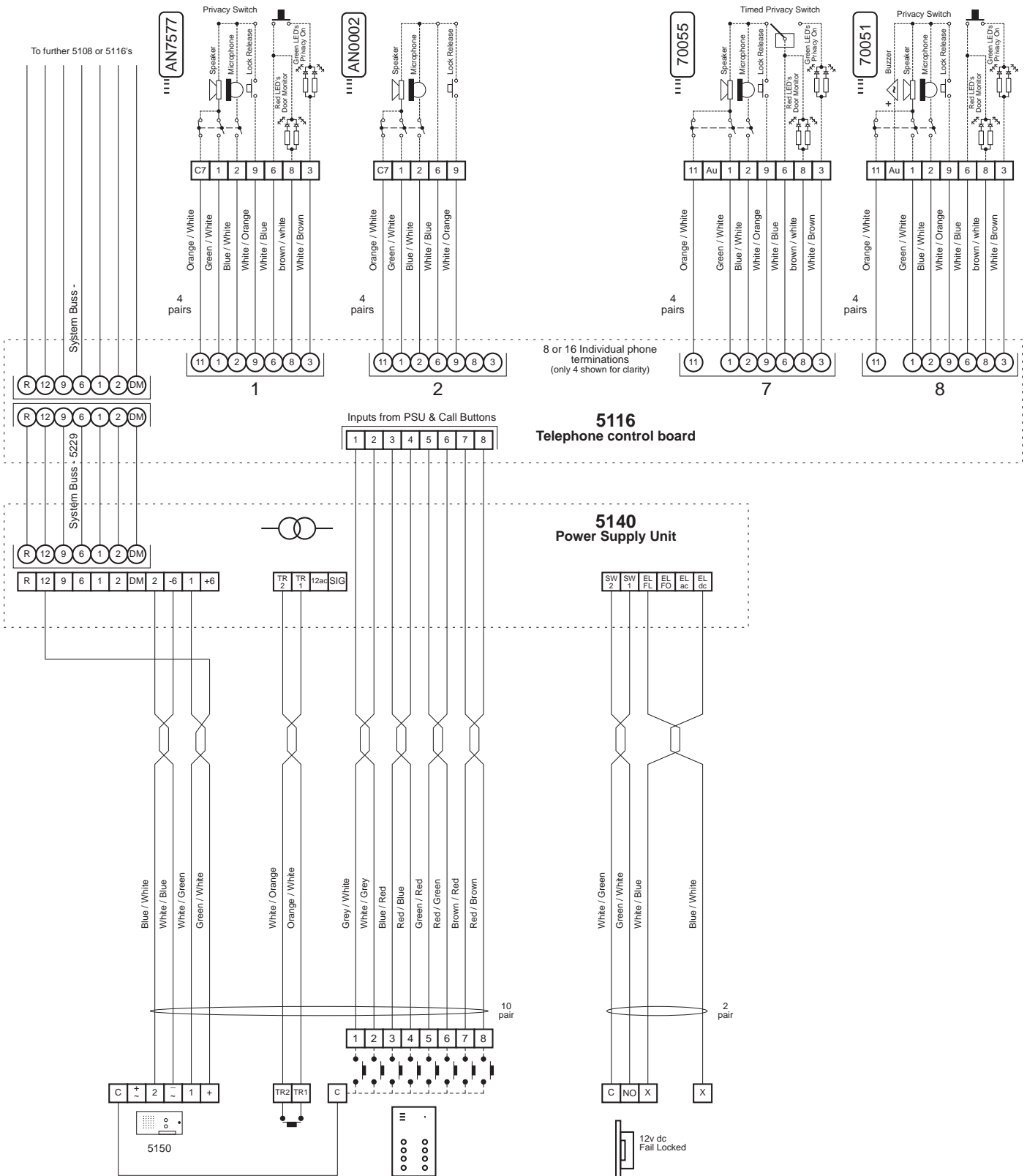

Standard Functional system

Drawing 3D_5140 2ESF 970919SS

- tone call
- two entrance panels

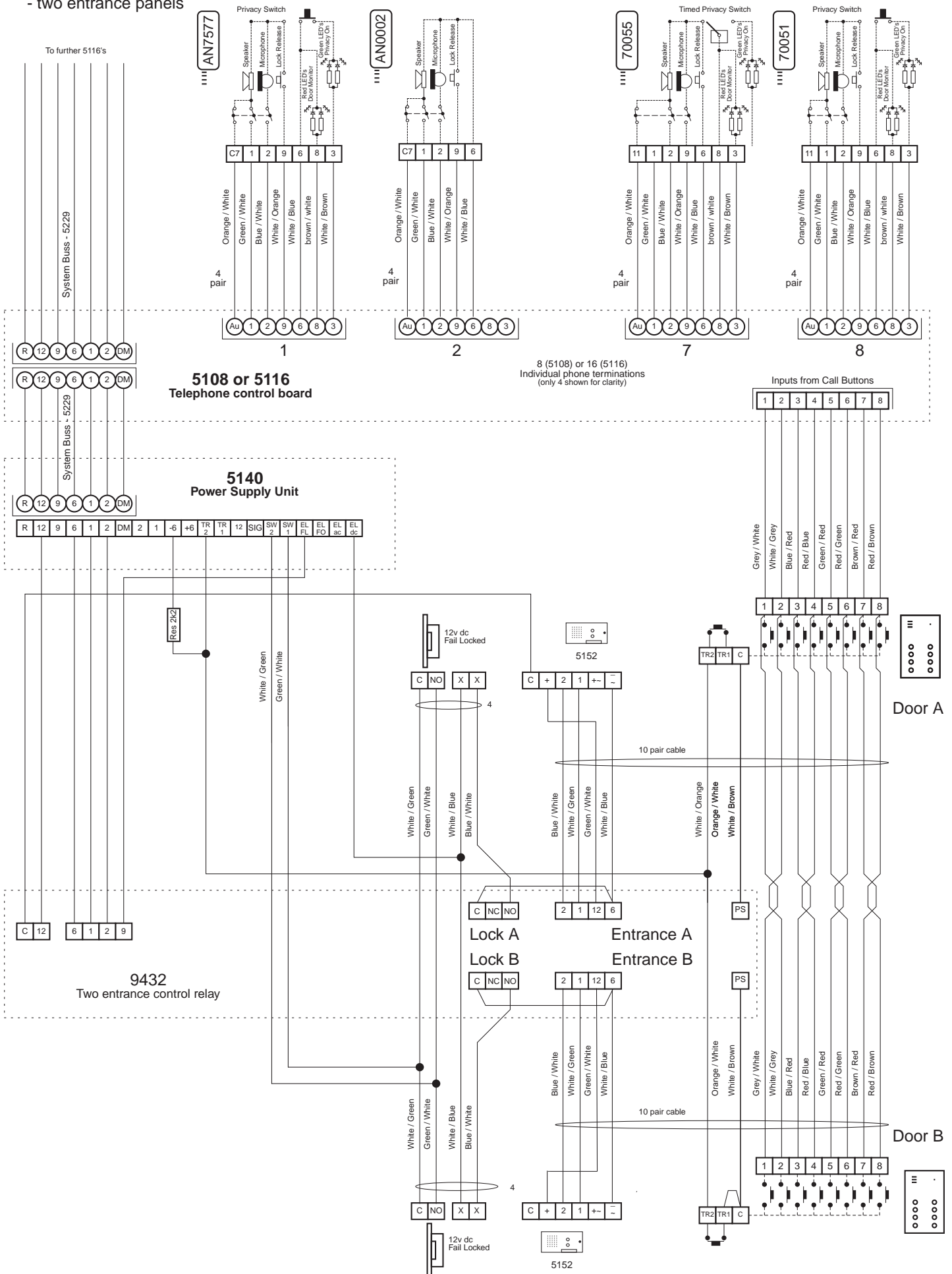

Isolated system

Drawing 3D_5140 1E IS 970919

- electronic tone call
- one entrance panel

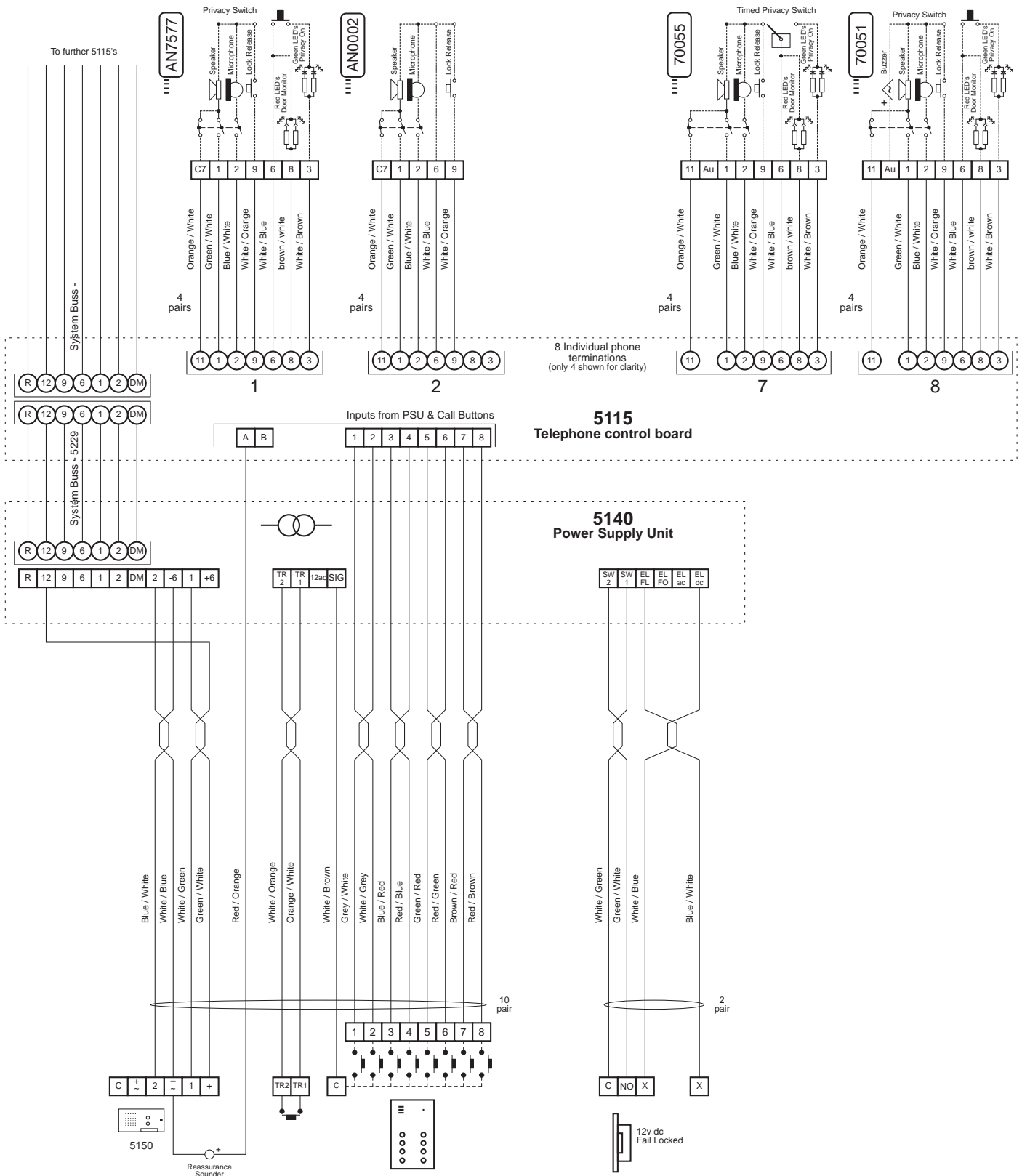

Key to Symbols

- Pre wired
- Installer connections
- 3 Screw Terminal
- 8 Plug In (crimp)
- 12v Piezzo
- LED

Isolated system

Drawing 3D_5140 2E IS 970919

- electronic tone call
- two entrance panels

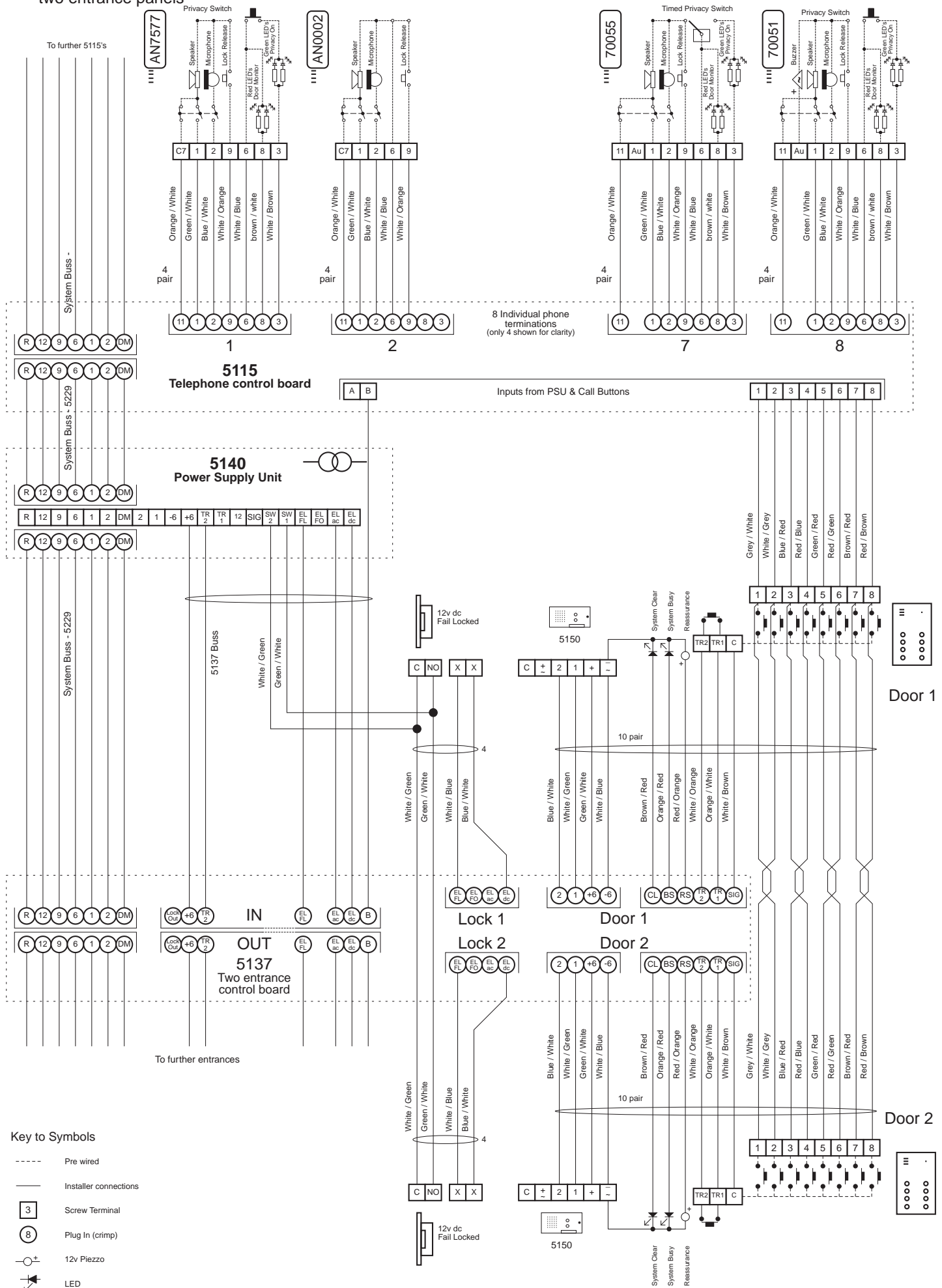

SPEECH SYSTEM

Testing circuits through 5115

(Isolated systems only)

I no speech from the telephone to the external panel

test continuity through the 5115. Test for zero resistance from terminal 2 on the 5140 board to terminal 2 on the affected telephone (Note you must call the telephone in order for this connection to be made.)

II no speech from the external panel to the telephone

test continuity through the 5115. Test for zero resistance from terminal 1 on the 5140 board to terminal 1 on the affected telephone (Note you must call the telephone in order for this connection to be made.)

III no speech in either direction

test continuity through the 5115. Test for zero resistance from terminal 6 on the 5140 board to terminal 6 on the affected telephone.

test for a combination of faults as in 1 & 11 above

A Lack of speech on one telephone

(Isolated systems only - also check 5115)

I If speech into the telephone cannot be heard at the entrance panel the fault is:

in the microphone in the telephone. Check continuity of microphone replace handset if necessary [resistance across terminal 2 and 6 with handset off should be approximately 100 ohms] and / or

in the cable from the telephone to the speaker unit. Check continuity of cables and replace cables if necessary [terminal 2 on the telephone to its junction with the common wires from terminal 2 on the audio amplifier]

II if speech into the entrance panel cannot be heard at the telephone the fault is:

in the speaker in the telephone (Check continuity of speaker [across terminal 1 and 6 with handset off should read approximately 40 ohms] replace handset if necessary) and / or

in the cable from the telephone (Check continuity of cables and replace cable if necessary [terminal 1 on the telephone to its junction with the common wires from terminal 1 on the amplifier]) **

III if speech not functioning in either direction the fault is;

a combination of the above faults and / or

in the cable from the telephone (Check continuity of cables [terminal 6 on the telephone to its junction with the common wires from terminal 6 on the audio amplifier] and replace cable if necessary). Terminal 6 on the telephone is the common negative return for all telephone functions including lock release and sounder, therefore if these functions are working then chances are that the negative return is OK and / or

wires to terminal 1 & 2 are reversed or shorted to another conductor.

B Problem with speech on more than one telephone but not all

I if the speech fault is not the same for all (affected) phones then the fault

should be treated as in A above but several times over and / or

any phones with common faults can be treated as C below

II if the speech fault is the same for all (affected) phones then the fault is:

a connection fault where several phones are junctioned together incorrectly and / or

a continuity fault where several phones are junctioned together and have either a short circuit, incorrect connection or a cable break.

C Lack of speech on all telephones

I If speech into the telephone cannot be heard at the entrance panel the fault is:

in the cable between the junction of the cables from the telephones and the audio amplifier (Check continuity and insulation from other conductors of cables [check between the junction of the wires from terminal 2 on the telephone and terminal 2 on the audio amplifier] and replace cable if necessary.) ** and / or

in the audio amplifier circuit between terminal 2 and the amplifier. (It is not possible to test the amplifier other than by exchanging it for one which is known to work) replace amplifier if necessary.

II if speech at the entrance panel cannot be heard at the telephone the fault is:

in the cable between the junction of the cables from the telephones and the audio amplifier (Check continuity and insulation from other conductors of cables [check between the junction of the wires from terminal 1 on the telephones and the terminal 1 on the audio amplifier] and replace cable if necessary.) ** and / or

in the audio amplifier circuit between terminal 1 and the microphone. (It is not possible to test the amplifier other than by exchanging it for one which is known to work (replace amplifier if necessary)

III If speech not functioning in either direction the fault is:

a combination of the above faults CI & CII and / or

in the cable between the junction of the cables from the telephones and the audio amplifier (Check continuity and insulation from other conductors of cables [check between the junction of the wires from terminal 6 on the telephones and terminal 6 on the audio amplifier] and replace cable if necessary.) Terminal 6 on the telephone is the common negative return for all telephone functions including lock release and sounder, therefore if these functions are working then the chances are that the negative return is OK and / or

wires to terminals 1 & 2 are reversed or shorted to another conductor and / or

no power to the amplifier (test for 6 volts whilst phone off hook across +6 & -6 at the amplifier. **

D Poor quality speech on system (whole or part)

I whistle or larsen effect - High pitched screech upon lifting handset is a sign of either:

excessive internal amplification (Volume requires adjustment) and / or

excessive external amplification (Volume requires adjustment) and / or

power supply too high (Check for 6volts) and / or

poor alignment of microphone to square hole in entrance panel plate and / or

incorrect cable used on long cable run (telephone cable - solid core twisted pairs should be used for all installations)

II poor volume at entrance panel speaker

too little external amplification (Volume requires adjustment) and / or

short circuit on wires 1 & 2 (Repair short circuit)

low voltage at amplifier (Test for 6volts across +6 & -6)

III poor volume at telephone earpiece

too little internal amplification (Volume requires adjustment)

short circuit on wires 1 & 2 (Repair short circuit) and / or

low voltage at amplifier (Test for 6 volts across +6 & -6)

LOCK RELEASE

A Lock release won't operate

I low voltage at lock

lock release coil short circuit (check resistance is approximately 20 - 50 ohms)

wrong voltage at lock release (ie.. ac instead of dc or vice versa check connection)

test for 12v ac or 12v dc at lock release terminals while energised and connected. A voltage reading may appear when no load is there but disappear when you connect the lock. If this happens carry out the same test with the lock release at the power supply to tell you whether the voltage is dropping away along the cable run or inside the power supply circuit board (assuming the lock release has tested OK). **

in the case of fail unlocked electric lock not opening remove TR1, TR2, System BUSS and terminal 9 and operate the LOCK RELEASE TEST button. If the LOCK ON LED lights and you hear the lock release click then test for negative voltage being removed on EL FO when the button is pressed. If the negative remains constant even when the LOCK ON LED lights then the power supply board is at fault.

II no voltage at lock

lock release coil short circuit (check resistance is approximately 20 - 50 ohms)

cable short circuit or break (check continuity of cable)

no voltage at power supply (check fuse LED is lit - if not then check fuse. If LED OK , check mains power and fuse are OK. If mains OK replace power supply pcb)

B Lock release won't switch off

I power at lock constant

lock release negative terminal (EL FL or EL FO) connected to negative permanently - check that EL FL and EL FO terminals switch a negative through to the lock.

LOCK ON LED remains lit permanently. To test remove TR1, TR2, System BUSS and terminal 9 from power supply pcb. Turn the LOCK RELEASE TIME ADJUST to zero if the LOCK ON LED stays on then the power supply is at fault.

TRADE CLOCK

A Trade on LED won't light up

I clock display operates correctly

if the display is working (ie.. it reads either ON or STY alternately when you press the MAN button) then the fault may be that the clock has not been Master Reset correctly. Press MAN and SET simultaneously (and hold for one second - note the power supply must be mains powered when you do this test) then operate the MAN button to switch on the TRADE ON LED on. If this does not clear the fault then replace the power supply board.

II clock display does not operate correctly

if the display is not working then check that the mains is connected and give the Ni Cad battery 5 minutes to get a basic charge. The clock has to be Master Reset. Press MAN and SET simultaneously (and hold for one second - note the power supply must be mains powered when you do this test) then operate the MAN button to switch the TRADE ON LED on. If this does not clear the fault then replace the power supply board.

B Trade on LED lights up OK but trade button doesn't work

I clock display operates correctly

Press the LOCK RELEASE TEST button, if lock release LED lights (and relay operates OK - see Lock release testing above) then turn TRADE ON LED on. Remove wires from TR1 and TR2. Connect a short piece of wire into TR2 and touch it into TR1 (not the screw head because this connection is often poor but into the terminal itself.) The lock release relay should operate. If it does not operate replace power supply board.

POWER FAILURES

A Power output LED'S off

I all LED's off

If no power is reaching the terminals at all then the fault is either at the mains fuse, mains power or the transformer. Test the above and remedy taking care to check that the mains plug to the transformer and the secondary plug from the transformer are making good contact. To test the low voltage power coming onto the power supply board - test for 12v ac across both pairs of pink - grey wires (pink, grey, pink, grey = 0, 12, 0, 12 respectively).

II lock - 12V dc LED off

Replace fuse and test for 12v dc across EL DC and EL FO with no external connections (LOCK ON LED must be off). If LED remains off yet you have 12v dc then LED is faulty. If you have no power then power supply board must be exchanged.

III battery charge - LED off

Replace fuse and test for 13.6v dc across battery leads with no external connections . If LED remains off yet you have 13.6v dc then LED is faulty. If you have no power then power supply board must be exchanged.

IV 12V ac LED off

Replace fuse and test for 12v ac across EL AC and EL FO with not external connections (LOCK ON LED must be off). If LED remains off yet you have 12v ac then LED is faulty. If you have no power then power supply board must be exchanged.

V 12V dc LED off

Replace fuse and test for 12v dc across 12 (+ve) and 6 (-ve) in the phone section with no external connections (including system BUS). If LED remains off yet you have 12v dc then LED is faulty. If you have no power then power supply board must be exchanged.

VI 6V dc LED off

Replace fuse and test for 6v dc across +6 and -6 with not external connections. If LED remains off yet you have 6v dc then LED is faulty. If you have no power then power supply board must be exchanged.

CALL TONE GENERATOR

(Isolated systems only)

A No call on telephone

I no call tone on one telephone

test terminal 11 output with a speaker or a telephone that you know to be working by plugging it in to the suspect socket.

II no call tone on all telephones associated with one 5115

test for 12v dc across terminals 6 (-ve) and 12 (+ve)

connect a short length of wire to SIG. Touch the free end on any call input (Numbered 1 to 8) to test a call. Test as described in (1) above test the call signal. If test fails, exchange the 5115 board, if OK check the wiring connections to the entrance panel.

B Incorrect telephones are called

I call one telephone and they all ring

test as for "No call on telephone" with call wires disconnected. This will establish whether the fault is with the 5115 board or the wiring.

II call one telephone and another telephone rings (always the same one)

the call button at the entrance panel of the telephone which always rings is permanently depressed or a short circuit is occurring on that call wire and / or

short circuit or interference from inductive load adjacent to call wires (check installation cables have been installed in accordance with the instructions (ie.. call wires run separately from any inductive loads etc.)

Dotted lines for note-taking.